

THE MASTHEAD PLANE

In 1953 the Soviet Union issued a request for design for a fighter capable of Mach 2, service ceiling 66,000 feet to combat the threat of the B-52 bomber. They also wanted it to be no larger than the MiG-19! By sacrificing a sophisticated intercept radar in favor of ground controlled intercepts, and shortening the combat radius to make it a point defense fighter, the MiG-21 was born.

The more observant of you may have already noticed that the masthead plane is not the tailed delta configuration of the MiG-21. It is, instead, one of the earlier proposals, called the Ye-2A. The swept wing design was more maneuverable, but lost out both in terms of load-carrying capacity and fuel capacity to the tailed delta version that became the MiG-21.

This would be a great model to puzzle your friends with. It looks like a MiG-19, but doesn't have the bifurcated air inlet in the nose, and the tail is less radical. Since it is so obscure, it will be easier to convince the judges that you've got the lines just right, too! Large wheels make it a grass-field jet worth looking at.



PROPWASH

VOL XXXIII, No.10 October, 2010

Mark Blair	president	313-534-9634
Ray Piper	vice-president	313-532-7286
Tim Kirsten	secretary	313-565-6093
Robert Huard	treasurer	313-565-5895
Charles Henry	safety	313-926-0961
Bill Gillespie III	field	313-333-0700
Al Zerber	membership	734-427-4872
Ken Goodlesky	at-large	313-584-9182
Ron Wasielewski	at-large	248-991-9336
Charles Henry	at-large	313-926-0961
Mike Cuba	editor	734-522-7638
Charlie Thomas	swap shop	313-565-2973
Bob Mayhew	photo archivist	313-291-6855
Mike Cuba	newsletter archivist	734-812-0102
Nick Kyriacou	video archivist	313-277-0908
Vince Blasky	webmaster	248-228-4945
Mike Archangeli	webmaster	313-386-7401

website <http://detroitaeromodelers.com>

STAN SPIEWAK

Stan Spiewak is back home again after successful hip surgery. He's doing rehab now, and according to his son, is bouncing all around the house! The doc said it was the worst hip he'd ever seen, but now Stan's feeling no pain. Congratulations, Stan!

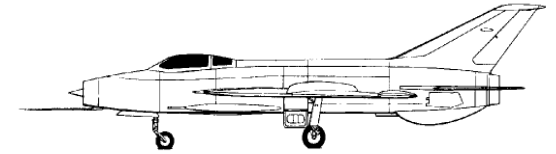

ELECTION NEWS

Nominations for office will be taken at the December meeting, with the election in January. We need officers! AMA will not charter us unless we have an elected president, vice-president, secretary, treasurer, and safety officer. No charter, no agreement with Detroit. No agreement, no flying field! Now is your chance to put into action all the wonderful plans you have! Run for office. It's easy...even I've done it!

INDOOR FLYING

Does anyone in the club belong to Ward Presbyterian on Six Mile just west of Haggerty? Last year I saw a couple of guys coming out of there with indoor electrics. They have a nice gym, and fly there regularly. We need a contact to find out more about this opportunity. If you know anything about this, contact president **Mark Blair** with the info.

Nick Kyriacou's wife is once again offering the vestibule of the building where she runs "You Dirty Dog" dog grooming as a site for small helicopter flying. The area is available the first and third Friday of the month, at 6:30 p.m.

DOOR PRIZE AND RAFFLE

Bob Mayhew won the \$15.00 **Nankin Hardware** gift certificates, and **Frank Hanson** won the \$25.00 raffle prize from **Nankin Hardware & Hobby**. Thank you, Nankin!

Midwest Swap	11/7	9 a.m.
Business meeting	11/9	7 p.m.

FIELD NEWS

The combination to the porta-john is posted inside the frequency impound box door.

As is his custom, **Bob Mayhew** will store and refurbish the field prop over the winter. Thanks, Bob!

The revised field rules were voted into effect at the October meeting. They will be posted at the field, and a copy will be sent to the Detroit City Council for their records.

APRIL STATIC DISPLAY

The annual Static Display contest will be held this year in April. ARF's and planes purchased at swaps, etc. will be shown, but only kit-built, plans-built, or scratch-built models will be eligible for prizes. The grand prize this time is an extra ticket for the door prize drawing! If that's not an incentive to build, I don't know what is!

ANNUAL BANQUET CHANGES

Due to the lower interest in holding an annual banquet at a restaurant, the club voted to buy pizza and pop for consumption at our December business meeting. Be there at 7 p.m. for the head count! Since the club is picking up the tab for this event, it is open to members only.

MEMBERSHIP

Memberships are now being taken for the 2011 flying season. Do it now! After the April meeting you'll have to pay a late fee.

SHOW AND TELL

Mike Cuba brought in a not-yet-flown foam Albatros from Fly Zone. The electric micro-plane spans about fifteen inches, and runs on a single LiPo cell, the same as a Vapor. The plane sports very nice painted markings and even has twin machine guns! All it lacks is a pilot!

Mike saw this plane, a new offering, advertised at Tower Hobbies for \$80, plus \$10 shipping. When he pointed this out to the guys at Nankin (Nine Mile) where it was priced at \$100, they immediately retagged it at \$90. It's nice to know that they are willing to match prices.

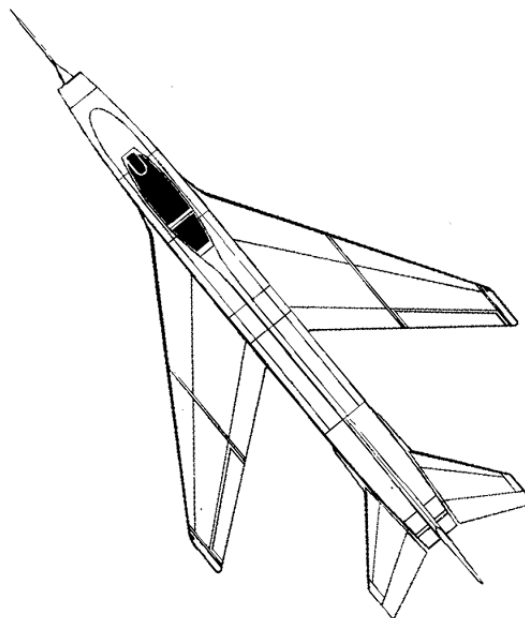

ARCHIVE NEWS

Three DAM members are now holding the archives of the club. **Bob Mayhew** will continue to maintain and expand the photo albums. **Nick Kyriacou** continues to maintain our video library. **Mike Cuba** will take over the paper archives, primarily the old **PropWash** newsletters.

PROPWASH

31425 Myrna, Livonia, Mi. 48154